

POWERSTAR PMG-4.5SH

4.5kW(50Hz)

Generator Specifications

Output	4.5 kW
Voltage	230 V
Phase	Single-phase
Weight	100kg
Frequency	50 Hz
Revolution	3000 rpm
Dimension	560*473*598 mm

Alternator Specifications

Frequency	50 Hz
Voltage	230 V
Power	7 kW

Controller Specifications

Working Voltage	8.0V-35.0V DC Continuous power supply
Power Consumption	< 3W(Standby ≤ 2W)
Overall Dimension	135mm*110mm*44mm
Installation	116mm*90mm

MINI Series



Diesel Engine Specifications

Output	7.5W
Revolution	3000 rpm
Cylinder	1
Aspiration	Self-priming
Bore	88mm
Stroke	75mm
Weight	50 kg

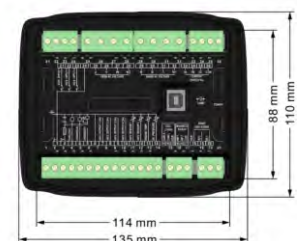

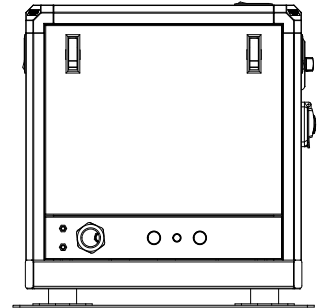
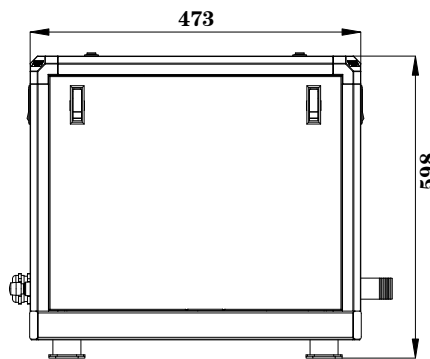
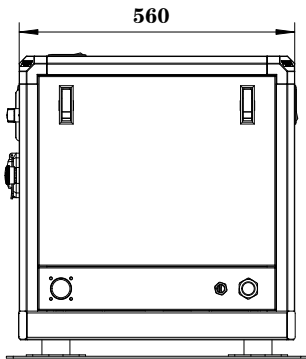

Installation Dimension

Exhaust Pipe mm	45
Water Inlet Pipe mm	20
Oil Inlet Pipe mm	8
Oil Return Pipe mm	8
Battery Capacity AH	100

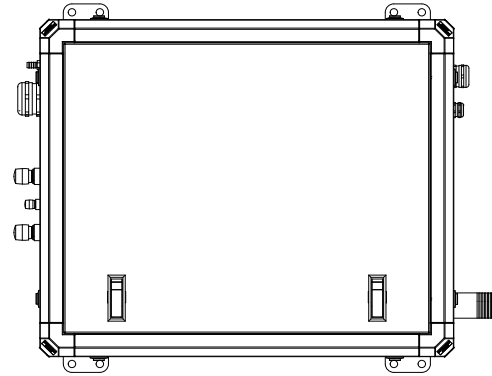

Standard Configuration



- Remote Panel
- 15m Remote Cable
- Sea Water Filter
- Generator Self-protection Shutdown: High water temperature, low oil pressure, high speed
- Oil Water Separator
- Water Intake
- Muffler