

POWERSTAR PMG-8SH

8kW(50Hz)

MINI Series

Generator Specifications

Output	8 kW
Voltage	230 V
Phase	Single-phase
Weight	140kg
Frequency	50 Hz
Revolution	2300 rpm
Dimension	700*600*645 mm



Alternator Specifications

Frequency	50 Hz
Voltage	230 V
Power	10 kW

Diesel Engine Specifications

Output	6~14kW
Revolution	2300rpm
Cylinder	2
Aspiration	Self-priming
Bore	80mm
Stroke	79mm
Weight	58/60 kg

Controller Specifications

Working Voltage	8.0V-35.0V DC Continuous power supply
Power Consumption	< 3W(Standby ≤ 2W)
Overall Dimension	135mm*110mm*44mm
Installation	116mm*90mm

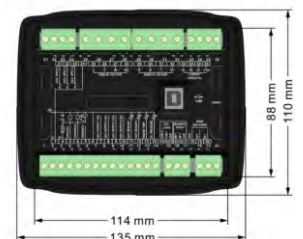

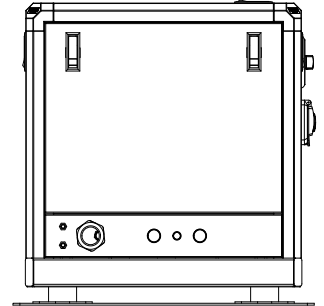
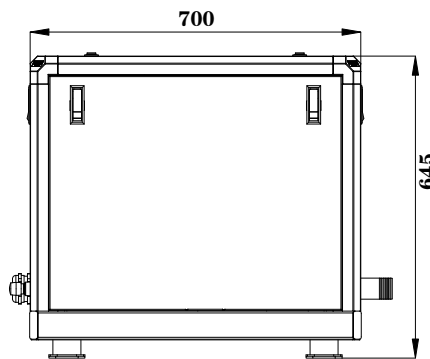
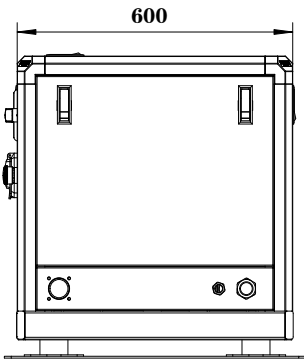

Installation Dimention

Exhaust Pipe mm	45
Water Inlet Pipe mm	20
Oil Inlet Pipe mm	8
Oil Return Pipe mm	8
Battery Capacity AH	100

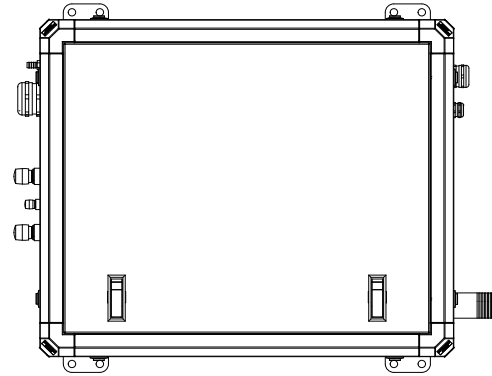

Standard Configuration



- Remote Panel
- 15m Remote Cable
- Sea Water Filter
- Generator Self-protection Shutdown: High water temperature, low oil pressure, high speed
- Oil Water Separator
- Water Intake
- Muffler