

# POWERSTAR PMG-12SL

## 12kW(50Hz)

### MINI Series

#### Generator Specifications

Output	12 kW
Voltage	230 V
Phase	Single-phase
Weight	240kg
Frequency	50 Hz
Revolution	1800 rpm
Dimension	900*562*680mm



#### Alternator Specifications

Frequency	50 Hz
Voltage	230 V
Power	20 kW

#### Diesel Engine Specifications

Output	18.5kW
Revolution	1800rpm
Cylinder	3
Aspiration	Self-priming
Bore	78mm
Stroke	85mm
Weight	115 kg

#### Controller Specifications

Working Voltage	8.0V-35.0V DC Continuous power supply
Power Consumption	< 3W(Standby ≤ 2W)
Overall Dimension	135mm*110mm*44mm
Installation	116mm*90mm

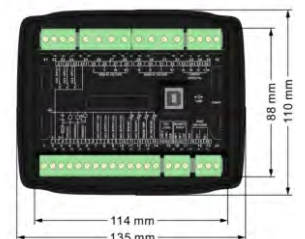

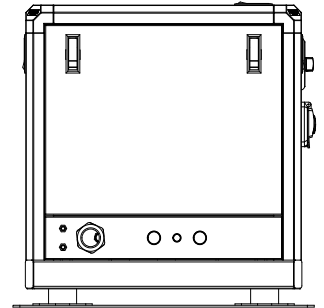
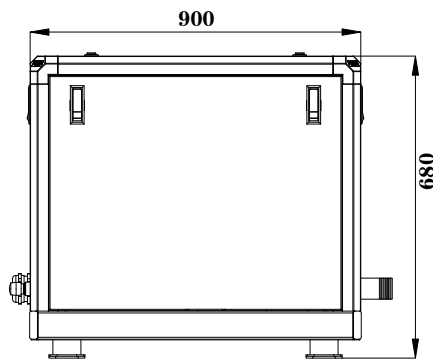
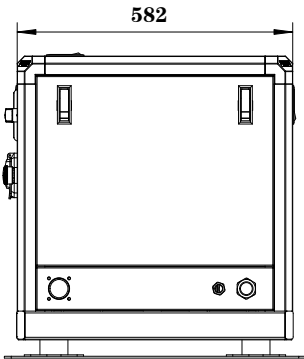

### Installation Dimention

Exhaust Pipe mm	45
Water Inlet Pipe mm	20
Oil Inlet Pipe mm	8
Oil Return Pipe mm	8
Battery Capacity AH	100

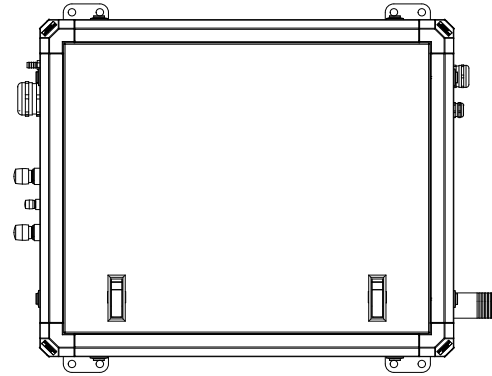

### Standard Configuration



- Remote Panel
- 15m Remote Cable
- Sea Water Filter
- Generator Self-protection Shutdown: High water temperature, low oil pressure, high speed
- Oil Water Separator
- Water Intake
- Muffler